

# 两片式德标球阀（轻体）

# KX VALVE

## 2-PC BALL VALVE -DIN3202-M3

WWW.KXCASTING.COM info@hbkaixuan.com

设计标准 (DESIGN STANDARD) : ASME B16.34 GB/T12237

螺纹标准 (THREADED ENDS) : BSP、DIN259、DIN EN ISO228、

产品型号 (PRODUCT STYLE) : Q11F-1000WOG (P/R)

公称压力 (WORKING PRESSURE) : PN63

适用温度 (TEMPERATURE RANGE) : -20°C~180°C

材 质 (MATERIAL) : ASTM-A351-CF8M、ASTM-A351-CF8

检验标准 (TEST&INSPECTION) : API598 JB/T9092

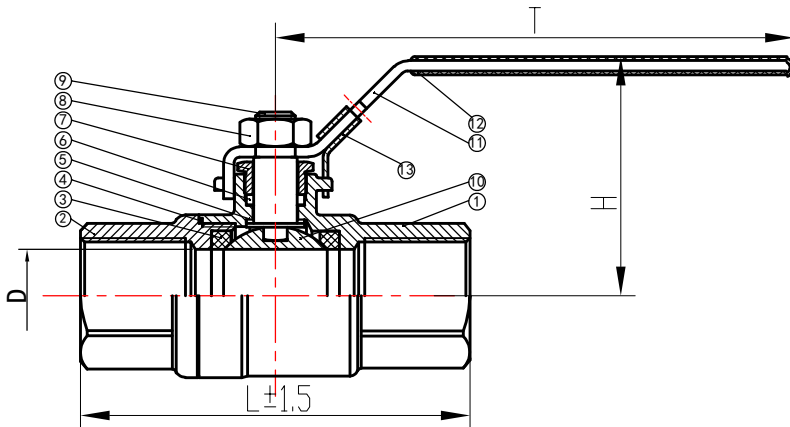

### 主要零部件材料 (MAIN PARTS MATERIALS) :

序号 NO.	零件名称 PART NAME	材质 MATERIAL	数量 QTY
1	阀体 BODY	CF8/CF8M	1
2	阀盖 CAP	CF8/CF8M	1
3	阀座 SEAT	PTFE/RPTFE	2
4	密封圈 JOINT GASKET	PTFE/RPTFE	1
5	止推垫圈 THRUST WASHER	PTFE/RPTFE	1
6	填料 PACKING	PTFE/RPTFE	1
7	压盖 GLAND	SS304	1
8	螺母 NUT	SS304	1
9	阀杆 STEM	S304/S316	1
10	球体 BALL	S304/S316	1
11	手柄 HANDLE	S201	1
12	手柄套 HANDLE COVER	PVC	1
13	锁 LOCK	S201	1

### 主要尺寸 (MAIN SIZE) :

SIZE	1/2"	3/4"	1"	1 <sup>1</sup> / <sub>4</sub> "	1 <sup>1</sup> / <sub>2</sub> "	2"
DN	15	20	25	32	40	50
D	15	18	24	32	35	44
L±1.5	75	80	90	110	120	140
H	58	64	70	76	84	89.5
T	99	104	111	141	141	160
KG	0.225	0.33	0.445	0.77	0.94	1.3